



PICKUP HELIUM OBSERVATIONS WITH STEREO PLASTIC A & B



**B. Klecker¹, E. Möbius², H. Kucharek², A.B. Galvin², K.D.C. Simunac²,
L. Ellis², L. M. Kistler², M.A. Popecki², and the PLASTIC Team**

WORK IN PROGRESS

¹Max-Planck-Institut für extraterrestrische Physik, Garching, Germany

***²Institute for the Study of Earth, Oceans & Space and Department of
Physics, University of New Hampshire, Durham, NH, USA***

***STEREO SWG 19
Pasadena, Ca, USA
February 3 - 5, 2009***



STEREO Pickup He Observations



- **Introduction**
Pickup He: Diagnostics of the Local Interstellar Medium
- **Motivation**
Learn more about the causes of the large variability of Pickup Ions
Use pickup ions to study M/Q dependent injection and acceleration (CIRs, IP shocks)
- **STEREO PLASTIC and Data Acquisition**
Data Analysis and Pickup Ion Spectra
- **Three Cone Traversals in 2007 (A, B) and 2008 (A)**
Pickup Ion Fluxes and Solar Wind Parameters
- **Summary & Conclusions**



Interstellar He Cone Observations

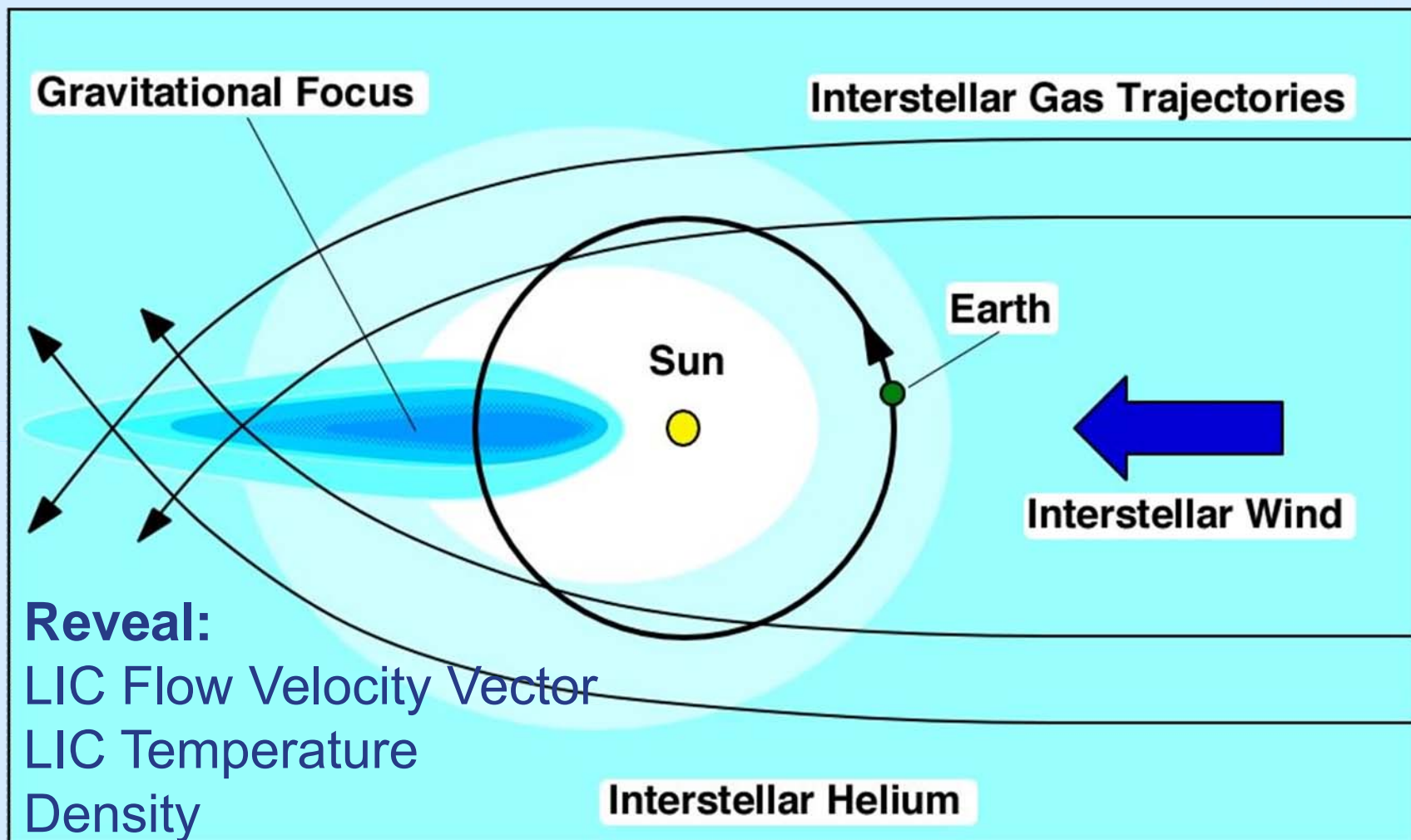



Combined He Cone PUI Observations AMPTE, ACE & NOZOMI

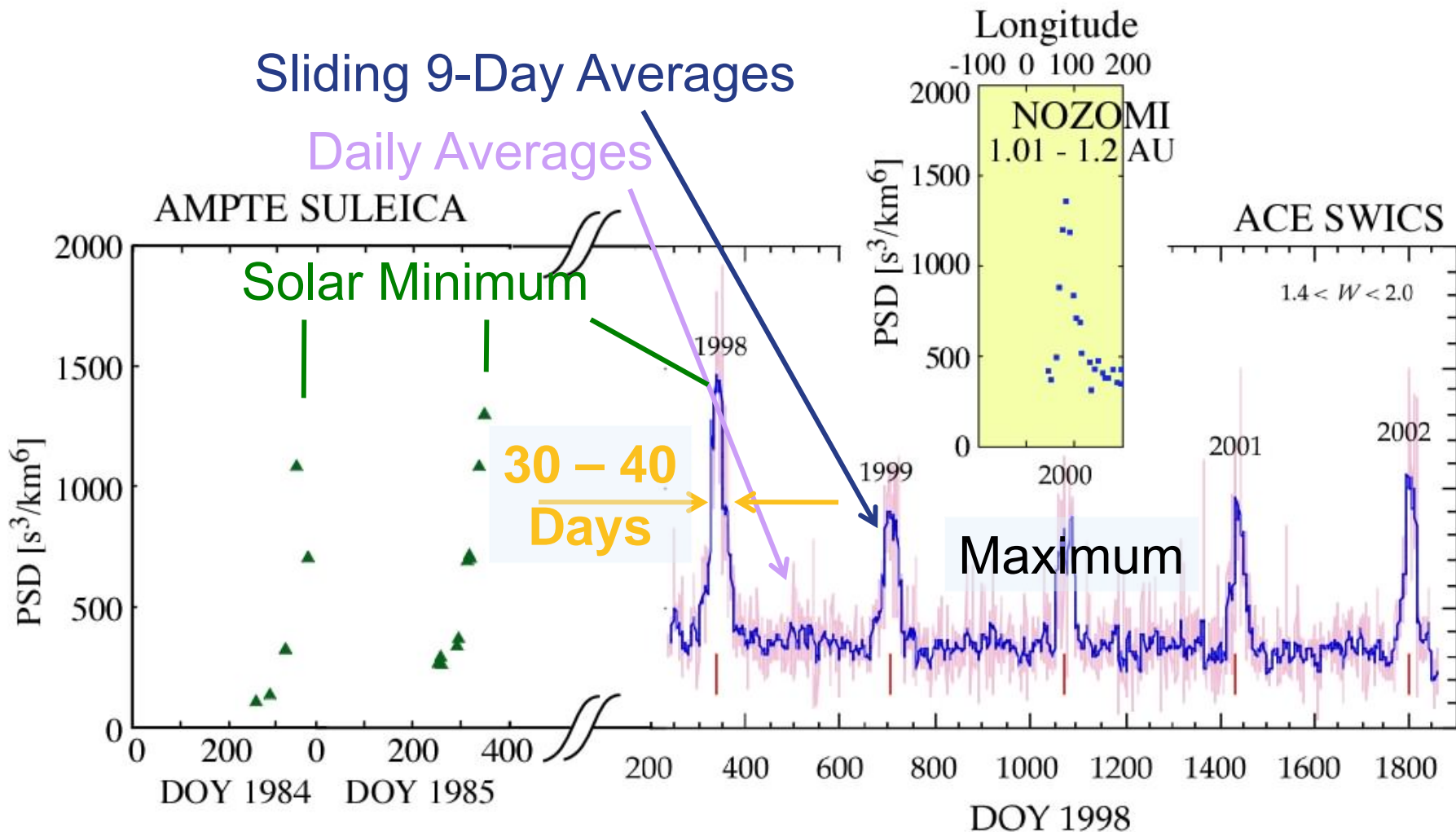

Möbius et al., 1985

Gloeckler et al., 2004



Strong Variations in Pickup Ion Distributions



- **Pickup Ion Distributions are Highly Variable**
- **Pickup Ions React to:**
 - IMF Orientation (early Rollover)
 - IMF Strength (Compression and Rarefaction)
 - SW Density (Compression and Rarefaction)
 - Ionization rates and probably several unknown causes
- **For Deduction of LIC Parameters Mitigation Sought with:**
 - Long Integration Times

Better: Attempt to Understand Causes
- **Study of Ion Transport, Injection and Acceleration Processes (M/Q-dependent)**
- **STEREO (also ACE) Provide Simultaneous Observations**



HE⁺ PICKUP IONS AT SUPRATHERMAL ENERGIES

Events Related to Interplanetary Shocks

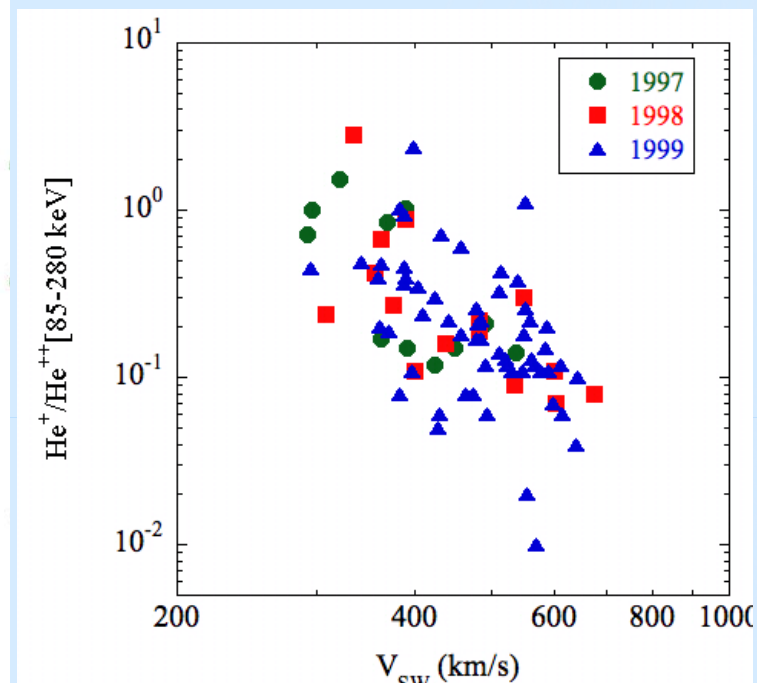
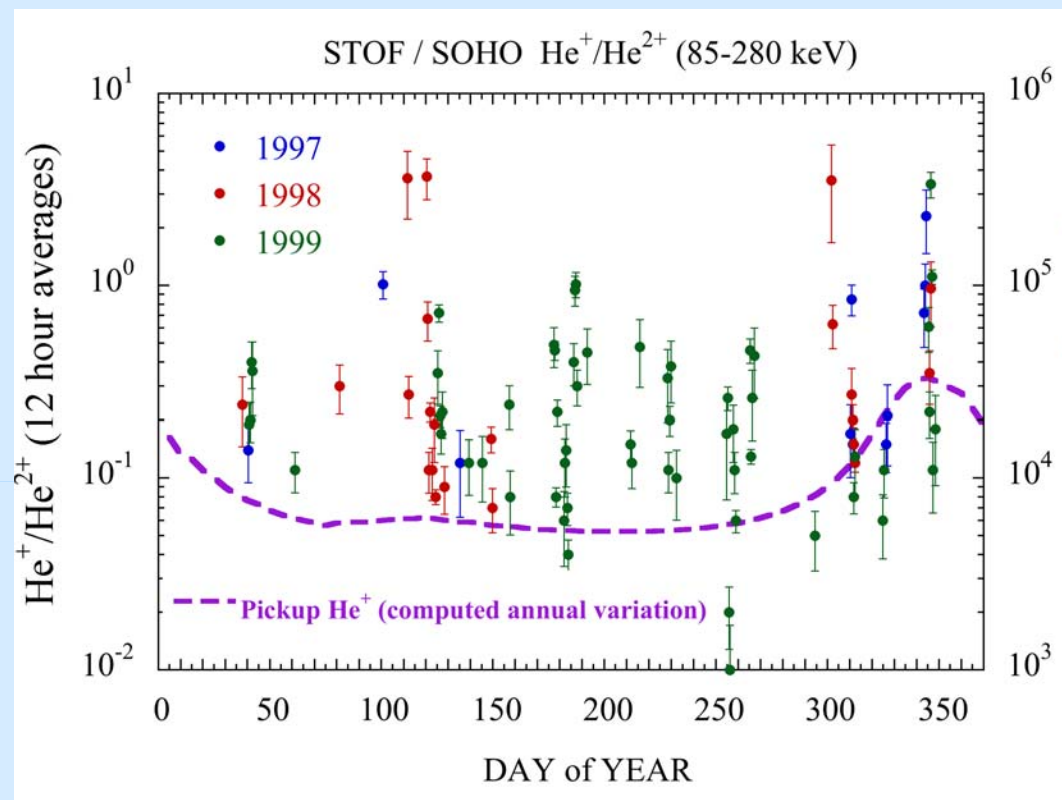

Anti-correlation of He⁺/He²⁺ with V_{sw}

- Hovestadt et al., 1984
- Gloeckler, et al., 1994
- Klecker et al., 2001
- Kucharek et al., 2003

STEREO: High Sensitivity will enable study of individual events and time variations on short time scales (~ few hours)



Simultaneous Interstellar He Cone Observations

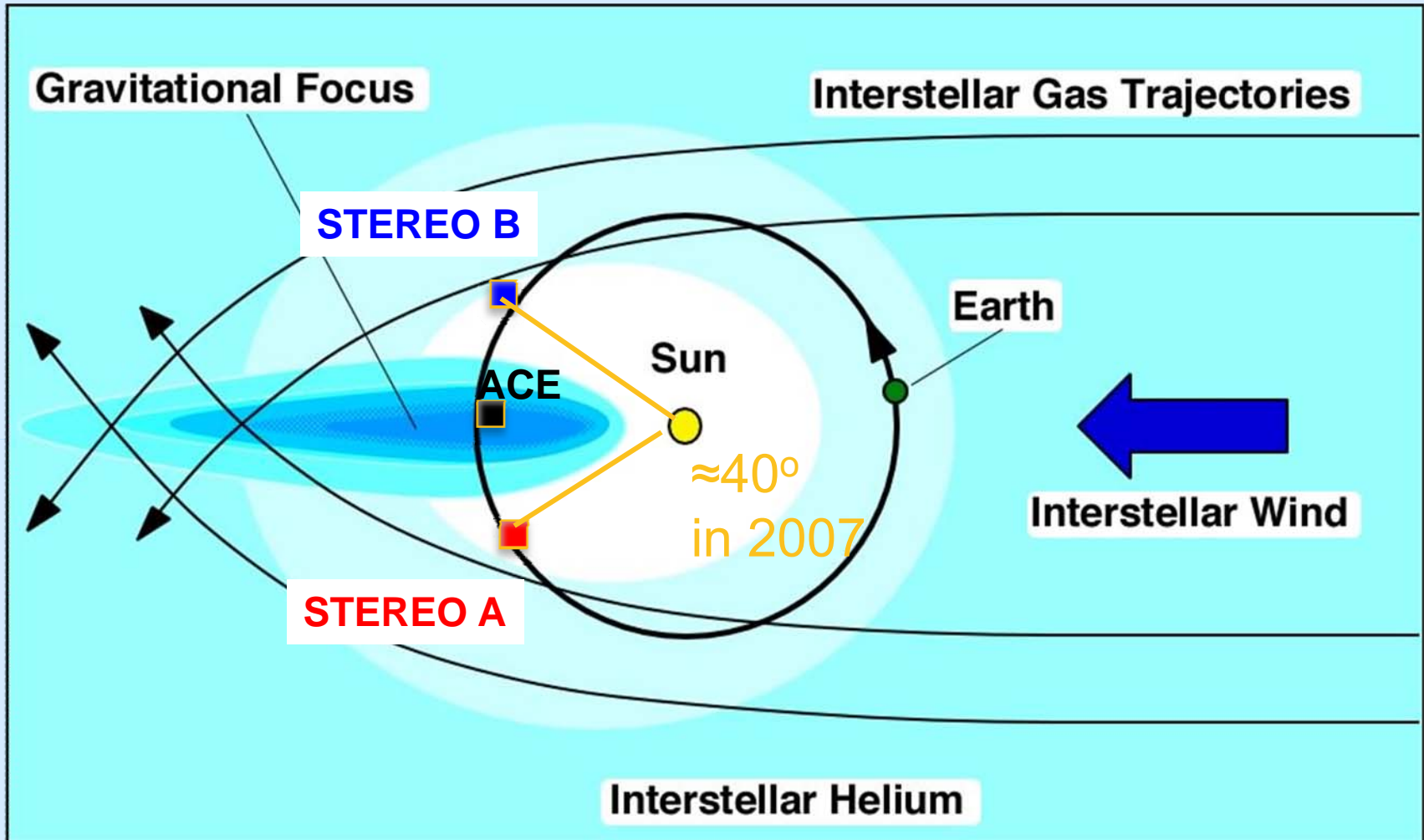



Simultaneous Interstellar He Cone Observations

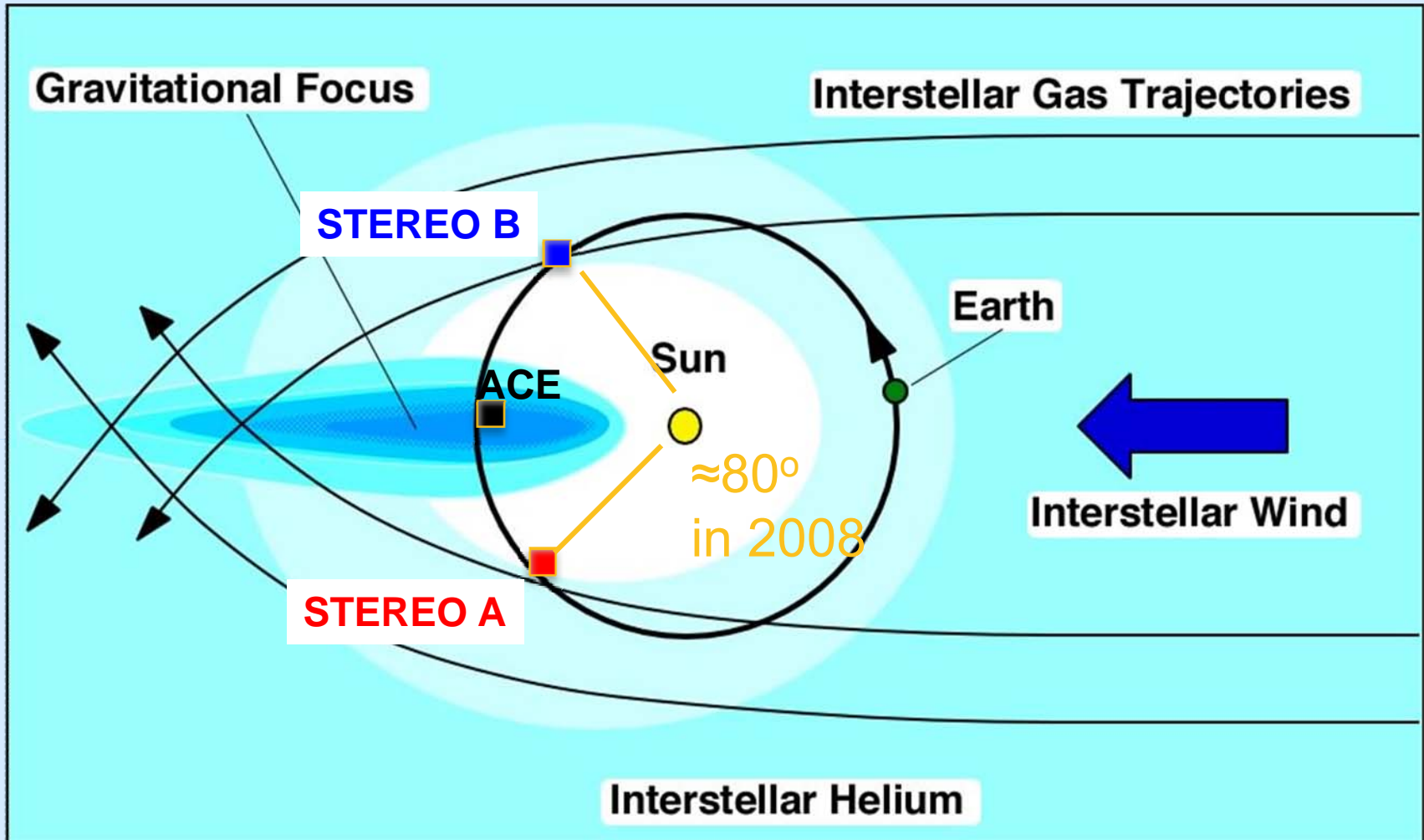

SUN

• STEREO PLASTIC Combines:

• Electrostatic Analyzer

• + Post-Acceleration → E/Q

• Time-of-Flight → E/A

• Solid State Detectors → E

A
Q
E

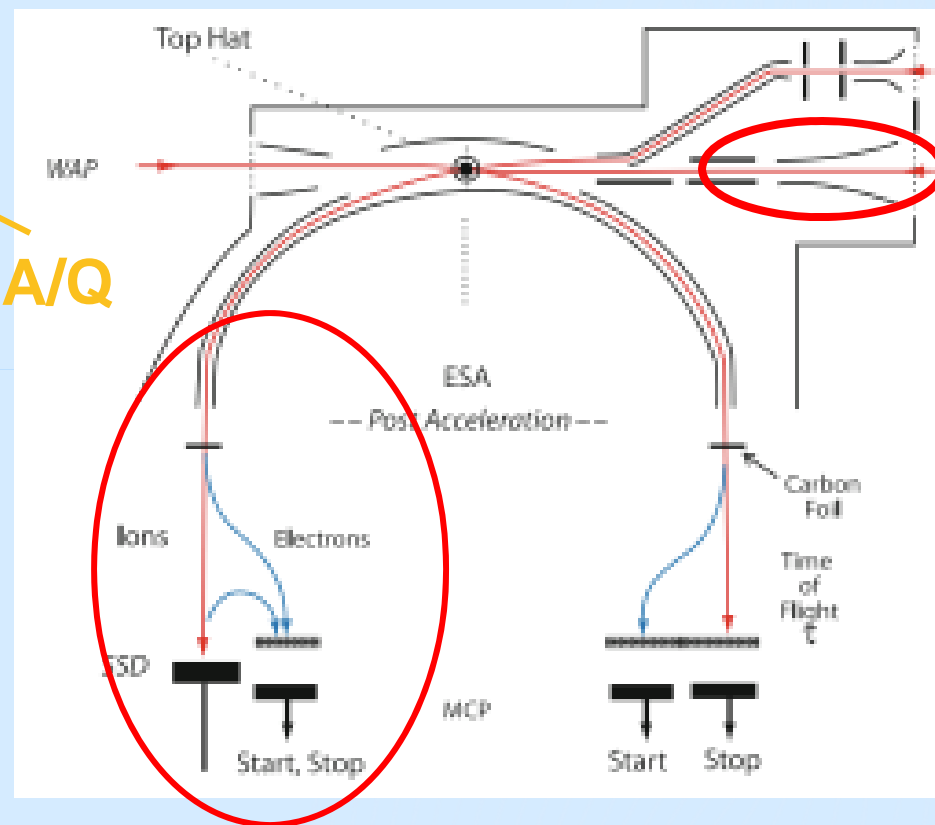

Data: Main Channel, Solar Wind Direction
(Double + Triple Coincidences)



He⁺ Analysis: PUI Spectra

- Accumulate all TOF Events with and without SSD
- Counts Normalized with Priority Rates
- Sort in V/V_{sw} Natural Frame for PUI Spectra
- Average over 24 h and $1.5 < V/V_{sw} < 1.9$

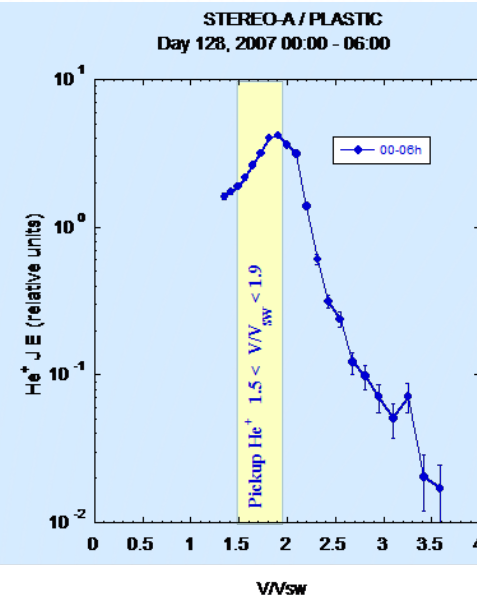
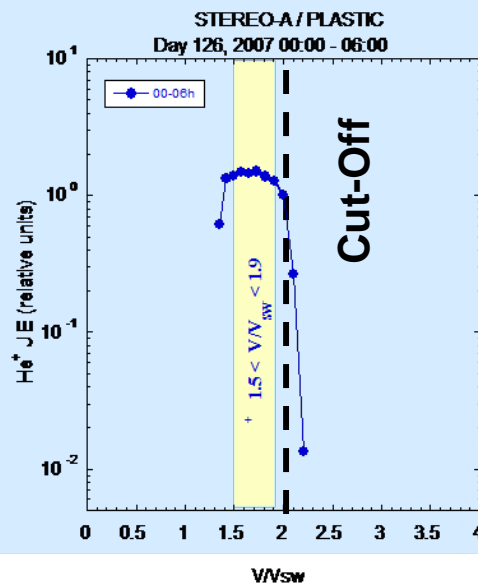
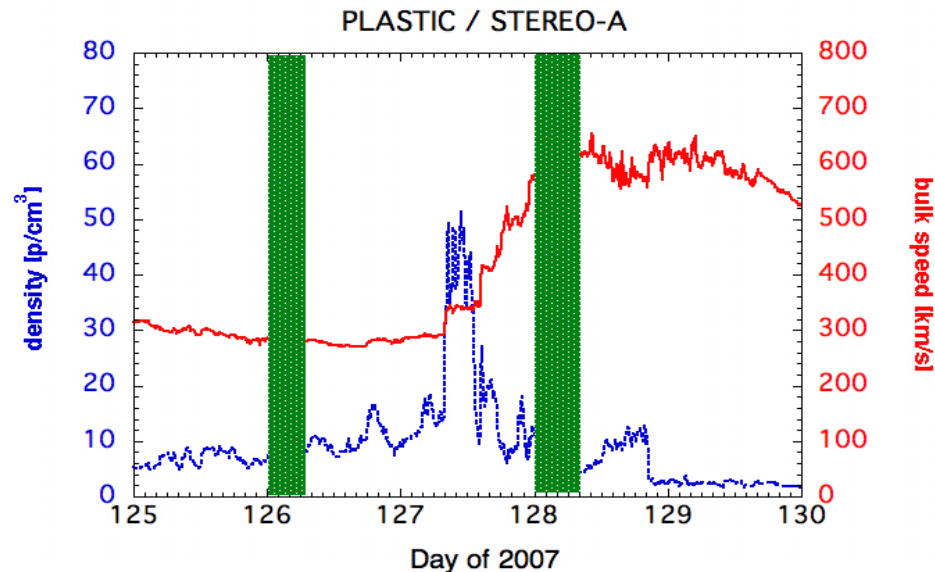
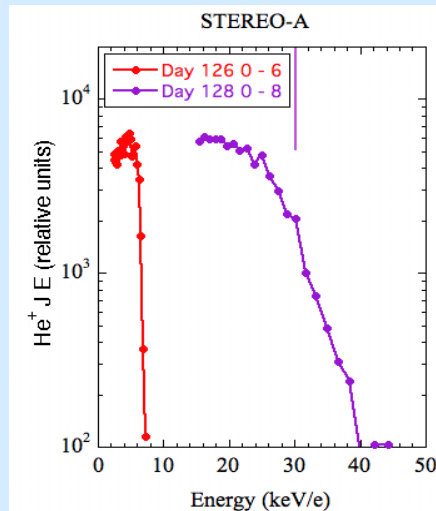



STEREO-A OBSERVATIONS IN 2007/2008

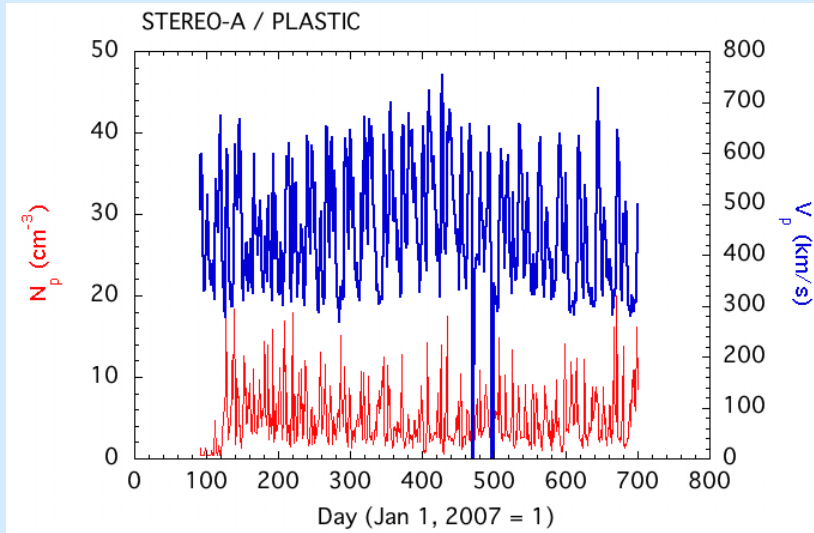

Solar Wind in 2007 and 2008:

- High Speed Streams and CIRs

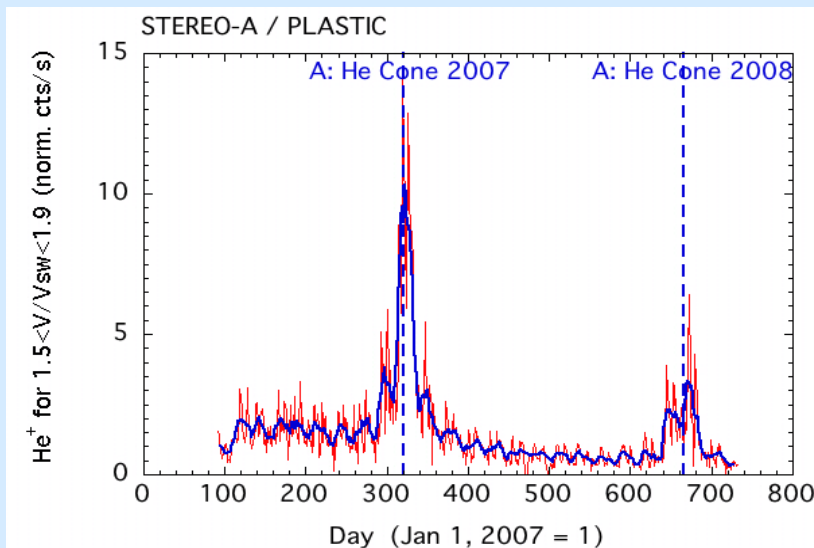

Pickup He^+

- Large variability of daily averages
- 9-day Sliding Average Smooths some of the known strong variations



STEREO-A

OBSERVATION OF FOCUSING CONE IN 2007

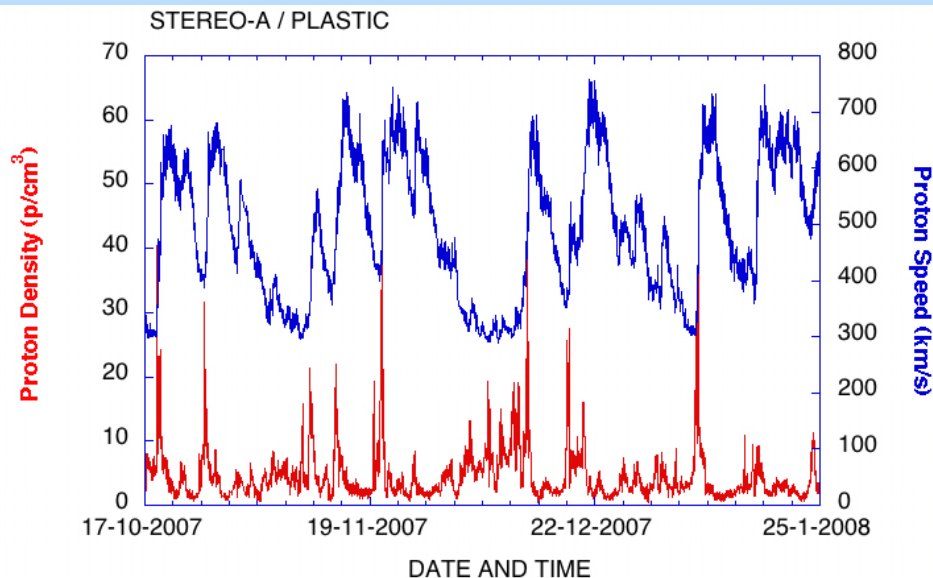

Solar Wind in 2007 and 2008:

- High Speed Streams and CIRs

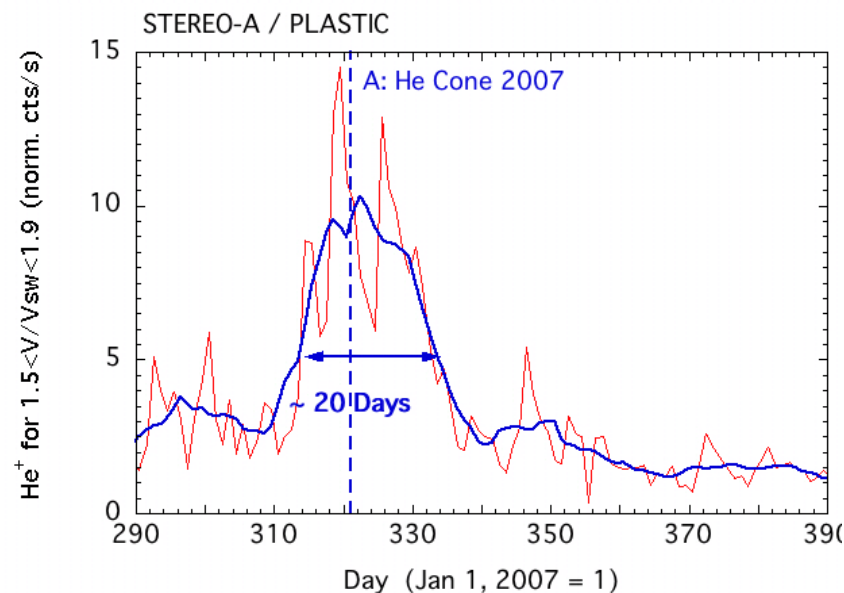

Pickup He^+

- Focusing Cone Fine Structure Influenced by High-Speed Streams
- Focusing Cone FWHM ~20 days



STEREO-A

OBSERVATION OF FOCUSING CONE IN 2008

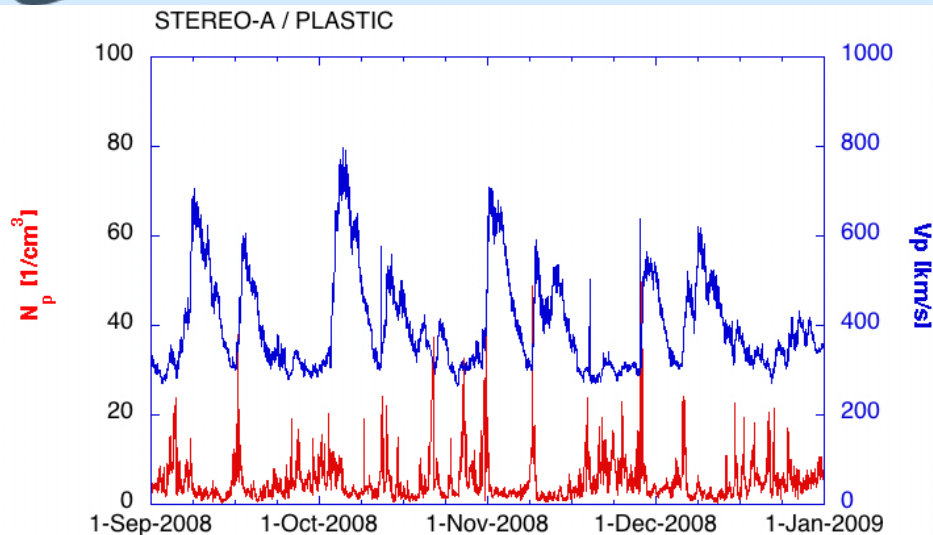

Solar Wind in 2008

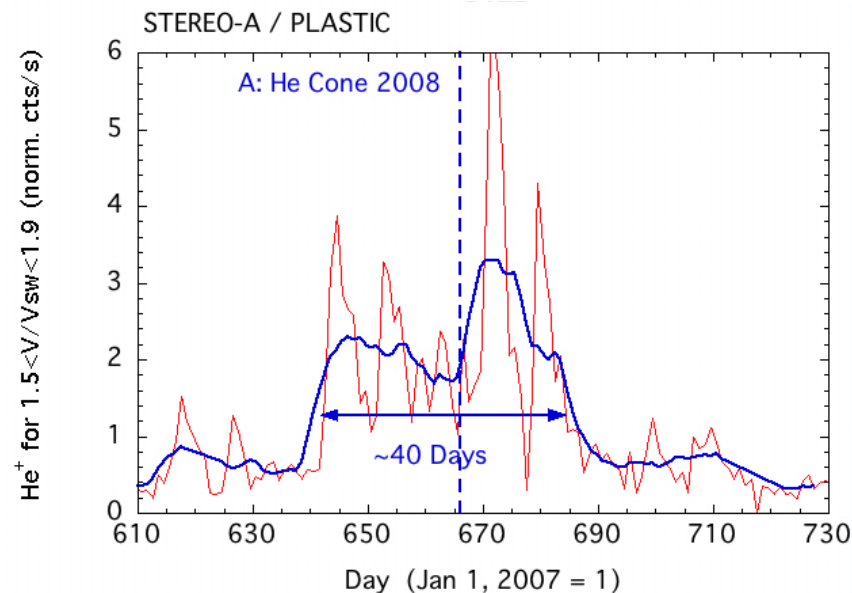

Pickup He⁺

- Focusing Cone Fine Structure and Large Scale Structure Strongly influenced by High-Speed Streams



STEREO-B

OBSERVATION OF FOCUSING CONE IN 2007/2008

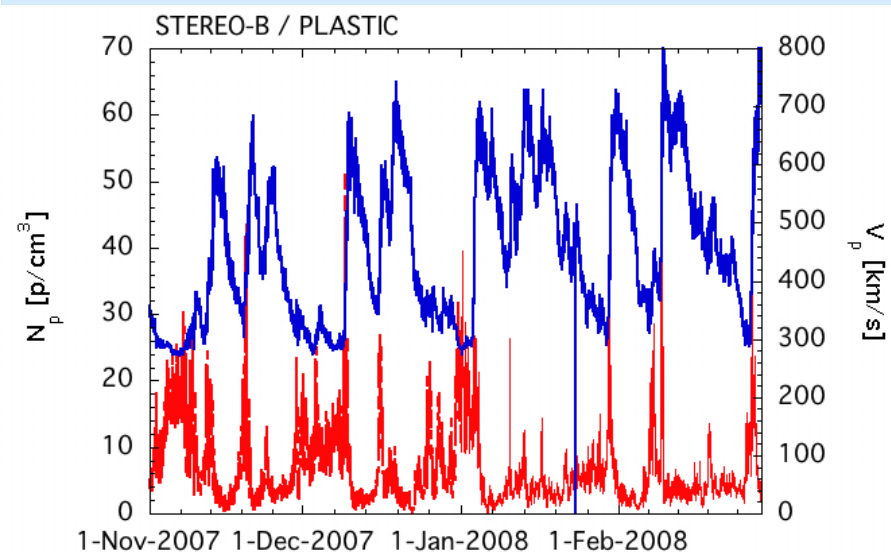

Solar Wind in 2007 and 2008:

- High Speed Streams and CIRs

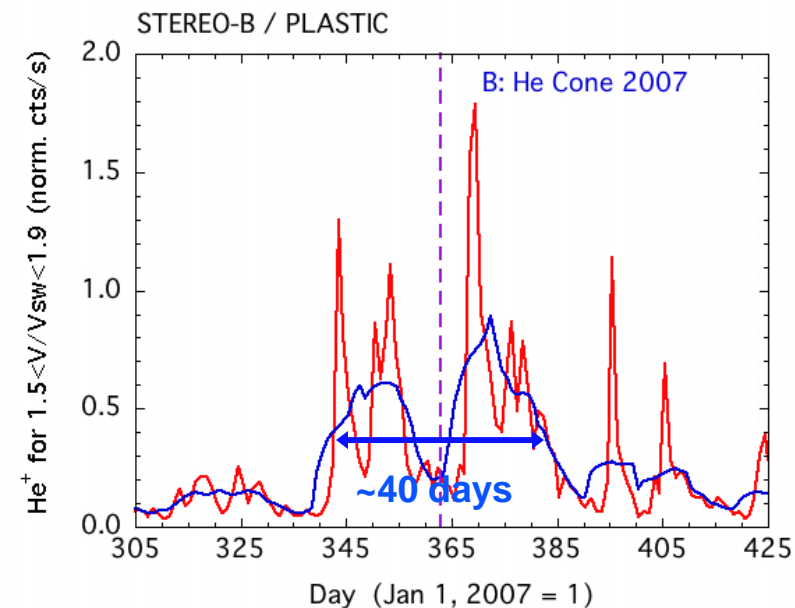

Pickup He⁺

- Focusing Cone Large Scale Structure Strongly Influenced by High-Speed Streams
- Focusing Cone FWHM ~40 days



Summary and Conclusions



- **Three Interstellar He Cone Traversals with STEREO A & B in 2007 and 2008**
- **Strong Daily Variations of Pickup Ion Distributions**
- **After Smoothing with 9-Day Sliding Average the 3 Cone Traversals Appear Substantially Different**
- **A 2007: Focusing Cone Fine Structure Influenced by High-Speed Streams**
- **B 2007 and A 2008: Large Scale Structure of Focusing Cone Influenced by Solar Wind Streams**

Next to do:

Convert normalized counts into flux using (time variable) efficiencies

Correlation of He⁺ variability on A and B, correlation with V_p , N_p , B , etc

Investigate Suprathermal tails of H⁺, He²⁺, and He⁺ in CIRs

- and in the CME-related IP shocks we all are waiting for